



A BRAND OF THE VEKA UK GROUP

Installation Guide

PVC-U Windows & Doors

1.0 INTRODUCTION

Installation guidelines have been based on manufacturing and installation knowledge of PVC-U windows and door-sets and British Standard BS8213-4. Due to the variety of installation conditions and building details found in the UK, it is not possible to cover all applications. The recommendations in this document shall be regarded as a guide to good building practices to ensure satisfactory installation of PVC-U windows and door-sets. You should refer to the fabricator's technical manual, or local building control office for specific technical advice. The Halo product range has been designed to meet the product specification required by the building regulations.

2.0 INSTALLATION MATERIALS

It is good practice for PVC-U frames, delivered to site, to have appropriate identification i.e performance, thermal efficiency and security marking, gross weight of the frame, customer name, contract number, location, aperture reference etc. Frames should be transported and stored in an upright position and placed on timber battens, wherever possible, to protect the frame edges and corners. They should be stored under cover or in containers away from direct sunlight and heating appliances. Where glass and frame travel separately, the beads can easily become detached from their frames and then get mixed up. The consequences of the wrong bead in a frame may result in an over tight bead fit which can cause corner weld failure especially in very cold conditions during installation. PVC-U frames are most at risk from mechanical damage during transport and should be handled carefully at times to avoid over stressing corner welds.

3.0 LOADING OF VEHICLES

- Always load products starting with the largest and finish with the smallest
- Any sealed units should be loaded and stored with protective packers/pads between the units to prevent damage
- When loaded all products should be suitably protected and restrained by rope or a suitable alternative
- REMEMBER: The driver is responsible for the safe loading of the vehicles. Care should be taken NOT to overload the vehicle

4.0 ARRIVAL AT SITE

Ensure the vehicle is parked taking into consideration safe access for the customer. Permission to park on drives should be obtained from the customer after introduction. The lead/foreman installer should ask to be shown around the property, drawing to the attention of the customer the removal of any furniture, fixtures or fittings that may otherwise be damaged during the installation. The lead installer should discuss and agree with the customer the installation schedule of works. The installers shall conduct themselves in a polite, courteous and professional manner at all times.

5.0 SITE PREPARATION

To ensure customers receive the highest quality of customer care and service you should observe:-

Do's

- Adequately protect the customer's property, both internally and externally
- Ensure that sufficient dust sheets or protective coverings are used in the immediate vicinity of the aperture(s) and placed in doorways, hallways and landings etc
- Take care NOT to soil or damage the floor coverings, decorations and furnishings
- Ensure that replacement products are installed on the same day as the originals are removed to maintain security and weathertightness of the property
- Cover the tops of ladders with a cloth or other suitable means if they are to be leant against cladding, shiplap, tiles etc. Ensure that ladders are secured and placed on a board to protect lawns and tarmac from damage

Don'ts

- You must not smoke tobacco inside the customers' premises
- Do not mix concrete, mortar or plaster on driveways, without the use of a mixing board
- Do not use scouring agents, solvents or thinning agents on the surface of the frames
- Do not use the customer's toilets unless permission is granted, then ensure the facility is left in a clean condition
- Do not use dust sheets on vinyl or laminated floors or on stairs. A non slip material should be used

6.0 REMOVAL OF EXISTING PRODUCTS

6.1 Golden rule

Before commencing with the removal of the existing product, check that the replacement product will fit into the aperture, inclusive of any tolerances allowed for by the Surveyor.

6.2 Pre-installation inspection

The Surveyor will have undertaken a detailed inspection of the building structure; however you should satisfy yourself that the structure is sound enough for the installation to take place.

6.3 Safety precautions

You should observe all appropriate Health and Safety requirements. The use of restricted area shall be considered as mandatory, this is to prevent any opportunity of injury to the homeowner.

- When handling broken glass, all operatives should wear safety goggles, cut resistant gloves, safety footwear and wrist protection
- All electrical powered tools MUST work either on 110 volts main power or be battery operated. Power operated grinding disks should only be used by fully trained operatives who must ensure that the sparks do not ignite any combustible materials
- When the presence of asbestos is suspected, then contact MUST stop work, report asbestos location and arrange removal by licenced contractor
- Old windows and door-sets remain hazardous even after removal. They should be moved from the site to a safe place of storage for eventual approved disposal. They should not be left in places accessible to children
- Removal of existing products at height should be carried out using a safe working platform (refer to Working at Height Regulations)

6.4 Removal of old frames

The safe and efficient removal of the old windows and doors is a critical stage of the installation. Damage may be caused to the reveals adjacent to the installation, and reasonable care must be taken to keep this to a minimum. Time and care taken on removal of the products will save time on completion – prevention is better than cure.

Timber Windows & Doors

- It is good practice to run a sharp knife between the inside face of the frame and the plaster adjoining the frame, to minimise the damage to the plaster and internal finishes when the frame is removed
- Opening sashes should be removed first, complete with their glass, by levering the screws from the frames, or unscrewing the hinges. This will provide the required working space
- Safe removal of the glass is imperative, preferably by removing the putty, sprags or fixing nails and removing the glazing completely with the use of glass lifting suckers. Alternatively, score the glass and break it carefully, so that the fragments are on the outside of the structure
- After removal of the sashes and fixed lights glazing, cut through any mullions and transoms (1) and remove them from the outer frame. If the original fixing nails or screws cannot be found and removed, it will be necessary to cut twice through the outer frame (2) to remove a small central piece of the outer frame. Then carefully lever the frame from the surrounding aperture – in the plane of the window – so as to cause the minimum of damage to the aperture

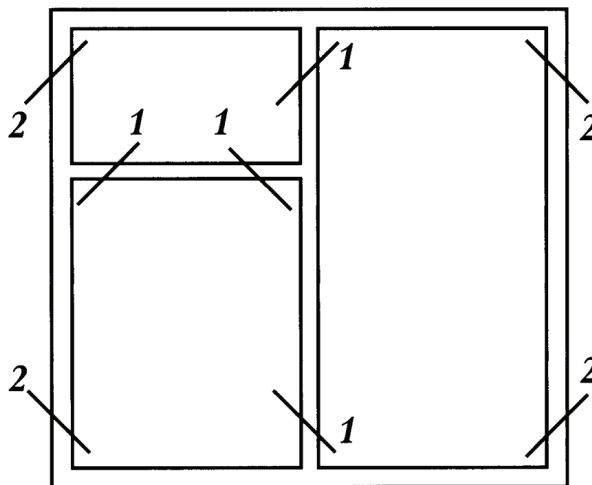

Metal Windows & Doors

- Steel windows set into timber sub-frames: Locate the screw holding the metal frame to the timber sub-frame, unscrew or punch the screw through steel frame. The glass may require removing to expose the fixings. Lever out the steel frame from the timber frame, then remove the timber sub-frame as described for timber windows
- Steel windows set directly into the brickwork or concrete: These windows are usually held in place by lugs attached to the outer frame. Locate the screws holding the metal frame to the fixing lugs, unscrew or punch screw through steel frame. The steel frame should be levered over the fixing lugs; care must be taken not to damage the fabric of the aperture. In certain conditions the use of an angle grinder to cut frame members may speed up the removal, EXTRA care must be taken to protect the customer property

PVC-U Windows and Doors

- All of the glazing should firstly be removed by removing the glazing beads. A sharp knife may be required to free the glass where glazing tapes have been used. Opening lights should be separated from the frame and removed. It is advisable to remove any trim profiles around the windows to allow easier access and to determine the presence of fixing brackets.
- Through-frame fixings can usually be unscrewed to allow the frame to be removed from the aperture. Care should be taken to avoid excessive damage to the fabric of the building.
- Where fixing brackets have been used to secure the window or door it is preferable to remove the screws from the fixing brackets. Where this is not possible, the brackets can be cut with an angle grinder. Extra care is needed to reduce the inevitable damage to the window or door surround.

Removal of sub-sills

- Sub-sills and heads are often 'horned' into the fabric of the aperture; great care must be taken when cutting and levering these items to reduce damage to plaster renders and brickwork to a minimum
- If the sub-sill is made from concrete, slate, bricks or tiles, then it may be left in position for re-use, providing any defects are remedied

Removal of box-sash windows

- Remove vertical stop beads, which retain the internal sliding glazed sash, chop through the sash cord, which will allow the counterbalance weight to drop for extraction later. Remove the sash
- Remove the vertical parting beads, which retain the external sliding glazed sash, chop through the sash cord, which will allow the counterbalance weight to drop for extraction later. Remove the sash
- Remove the mitred architrave from around the frame; remove the internal stub window board
- Remove the counterbalance weights from the pocket and then remove the timber sub-frame as described for timber windows

Removal of bay windows

- Before commencing any works the installers shall refer to the Surveyors details/installation instructions to determine load bearing requirements and head details
- In order to maintain the structural integrity when replacing a bay window, it is essential that temporary support be used, after determining the evaluation construction. Care must be taken to ensure that they are placed in such a position to support the structure without causing damage to ceilings or floors. In some cases temporary supports are needed both internally and externally
- After supporting the bay structure the windows should be removed carefully, ensuring that the minimum of damage is caused to the reveals, plaster finishings and trims. Any trims that will be re-used should be carefully checked for defects such as rotting and /or timber infestation
- It is recommended that load-bearing poles are removed one at a time and that both the temporary supports and the structure itself are closely monitored to check for any signs of settlement. Any heavy furniture in the upper floor bay area should be moved before removing the old bay window

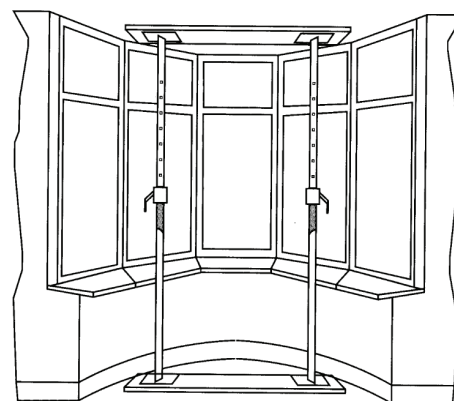

Bay window removal - Internal support

6.5 Preparation of the aperture

Brush down the masonry, check the condition of the DPM (if applicable). If the DPM is damaged this must be replaced prior to the installation of the products. Check the cavity is clear of debris and if a tray is fitted that it is not damaged.

6.6 Preparation of the product

- Remove weld sprue from the outer frame, which may obstruct the fitting of ancillary items
- Pre-drill the external overhanging sill (if applicable) with a 3.5mm drill bit at 300-400 mm centres. Invert the frame and apply a broad bead of low modulus silicone sealant along the length of the outer frame and returned across both ends. The overhanging sill can now be placed on to the outer frame and screwed in to place. For clip-on sills low modulus silicone sealant across both ends only. Turn the outer frame over and apply low modulus silicone sealant to the ends of the frame to prevent water seeping into the brickwork or plaster

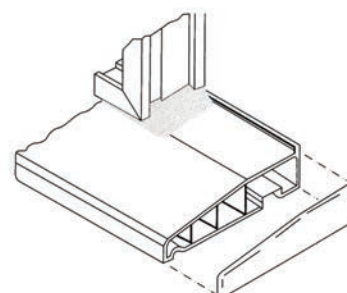

7.0 INSTALLATION OF REPLACEMENT PRODUCTS

7.1 Frame positioning

In general, replacement products should be positioned in the same position as the original frame. You consider:-

- The new frame should bridge the DPM and the required expansion gap should be maintained
- The new frame should be set back as far as possible within the aperture to shield it from the elements
- PVC-U windows and door-sets shall be installed plumb, level and square within the aperture, without twist or distortion of any frame member
- Particular attention is required to the frame positioning of door-sets. The clapping jamb should be set in alignment with the door leaf (twist)
- Each frame member should be fixed to the structure or to an adjacent frame to resist all likely imposed loads, which will cause the frame member to deflect
- The fixing methods should allow for thermal movement and will be influenced by:
 - The presence or absence of a wall cavity and the nature of any cavity
 - The relative position of the frame and cavity and the design of the reveal
 - The position of the plaster line and the need to preserve the interior decorations

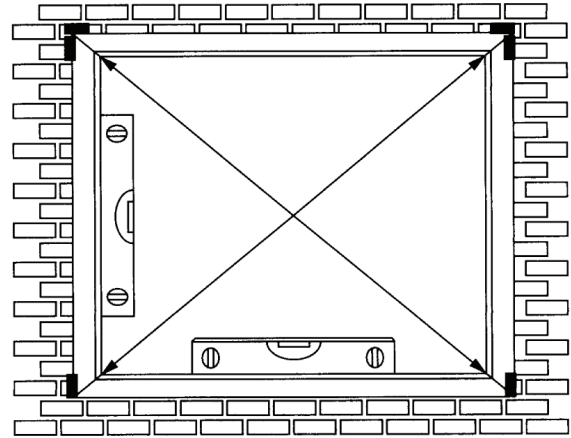

Recommended frame positioning checks

7.2 Fixing methods and fixing distances

There are two principal methods of fixing products used either separately, or in combination. These two methods are:-

- Through-frame fixings. The fixing should penetrate the substrate a minimum of 50 mm. The fixing head should be flush with the profile and neatly capped whenever exposed. Use fischer fixings or similar
- Lug fixings. If fixing lugs are used they shall be made from a non-corrosive material and used in combination with 'one way' or tamperproof screws. Any screws used must penetrate a minimum of 50mm into the substrate

Note: Construction foam should be used as a fixing assist or void filler only. Misuse of construction foam will distort PVC-U profiles.

In general, all four sides of the frame should be secured, wherever possible, using the following, recommended fixing distances and methods:-

- Corner fixings should be a minimum of 150 mm and a maximum of 250 mm in from the corner
- No transom or mullion fixings should be closer than 150 mm, or further than 250 mm from the centre of the transom or mullion. All intermediate fixings should be at centres no greater than 600mm
- All door-sets 'MUST' be fitted with the maximum number of through frame fixings appropriate to the size
- Installation packers should be used adjacent to fixing positions to prevent outerframe distortion during installation

7.3 Fixing at heads

Due to the presence of pre-cast or steel lintels it may be impractical or imposes severe difficulties in achieving the required number of fixings. Under these circumstances provided that the head of the frame has a continuous reinforcement, the opening is only at ground floor or first floor level and the exposure category does not exceed 1600Pa, the following guidelines can be considered:

- Frame width less than 1200 mm – no head fixing
- Frame width between 1200 mm to 2400 mm – 1 central fixing (or centre of each opening light)
- Frame width between 2401 mm and 3600 mm – 2 equally spaced fixings

If constructed foam is used, frame members should be checked for distortion.

7.4 Fixing at sills

Fixing at sills should be in accordance with the general guidelines. No fixings are required for sills up to 1000 mm wide provided that an adequate silicone or mortar bed has been achieved and the sill has been secured to the outer frame base by either screw fixings or clip-on feature.

7.5 Installation of replacement bay window assemblies

- Installation of the replacement bay window assembly should not start until any defects in the structure – such as faulty DPM's – have been rectified. Site conditions will determine whether the bay can be assembled prior to positioning, or whether the window will assemble 'in-situ.' Whichever method is used, checks should be made to ensure that no applied loads are carried by the individual segments of the window
- Bearing plates must always be used when loads are transferred from or to brickwork, stone or timber
- The most appropriate methods of transferring the load at sub-sill level from the pole to the structure is by passing the pole or special load bearing plate through the sub-sill to transfer the load directly onto the substrate (Diagram)
- When the bay pole rests on a load-bearing sub-sill it is essential that adequate provision be made to transfer the load from the sub-sill to the building structure without distortion of the sub-sill. This will usually necessitate the use of shims directly below all bay pole assemblies between the sub-sill and the substrate. The method of load transfer onto a reinforced subsill shall be mainly used for lightweight bays i.e. single storey bays, porches and conservatories
- Bay pole reinforcements should be pre-cut in a factory environment to ensure that the ends are cut square. This is of paramount importance to achieve correct loading transfer. The poles including bearing plates should be 5 mm longer than the actual bay window segments; the difference to head plate shall be made up with the shims
- Individual segments of any bay window assemblies should be fixed to the structure of the building and/or to the bay poles at the appropriate centres of 150 to 250 mm from the corners of the frames and at 600 mm maximum intermediate fixing centres
- Always commence building the bay window from the centre section to the wings

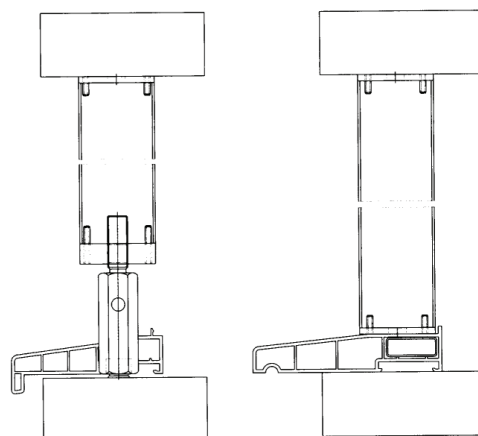

7.6 Perimeter sealing

- The purpose of the perimeter sealant is to prevent water and air leakage in the face of differential thermal expansion between the aperture and the frame for the frame's guarantee life. The use of low modulus silicone in accordance with BS 5889 type A is recommended for this application
- The optimum joint width required for effective sealing is a function of the movement that is expected in service. Therefore NO joint width should be less than 5 mm

- Gaps up to 6 mm in width can be sealed solely with a ribbon of silicone sealant. In all cases the sealant should fill the gap to a depth no less than the width of the gap; a backing strip may be used to limit the amount of silicone used. Such backing strips can be either Polyethylene foam, specially designed gaskets, compressible and/or expanded strips
- Gaps between 6 mm and 15 mm, the use of a backing material is essential
- Backing materials are also needed when the gap between frame and substrate varies such that the gap locally exceeds 6 mm. Special care should be taken not to seal the lintel cavity drainage path
- Gaps wider than 15 mm are not recommended. Where the installer is presented with gaps wider than 15 mm, due to mis-measure or local irregularity of brickwork, he should reduce the gap locally to the ideal design joint width using the appropriate PVC-U frame extension or trims

8.0 GLAZING

8.1 Glazing general

- All glazing shall comply with the requirements of BS 6262 and BS 8000 Pt 7. In addition any recommendations from glass or sealed unit manufactures should be followed
- Fully glazed PVC-U frames will necessitate de-glazing on site to enable fixings through the fixed lights. In that case the bead removal sequence depends on the position of bead within the frame

8.2 Site de-glazing

- Beads are removed by simple insertion of a putty knife and whilst pushing the bead towards the glass, lightly twist knife to force the bead out to its retaining channel

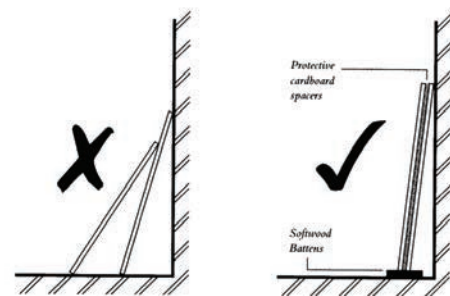
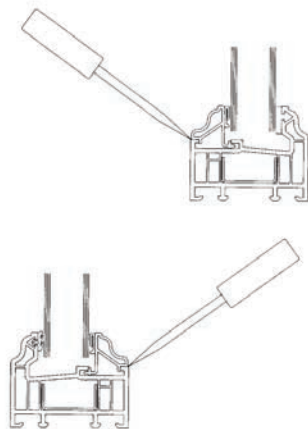

RECOMMENDED SITE STORAGE OF GLASS UNITS

8.3 Temporary glass storage

When glass units are temporarily taken out of the frame or are supplied separately and subsequently stored in site conditions, it is advisable to store them upright on softwood battens with cardboard spacers between the units to avoid any damage. When handling larger glass units, the use of suction pads is recommended. Special attention must be given when glazing on site in colder climatic conditions due to the inherent brittleness of the glass units and the increased stiffness of the rubber glazing seals

8.4 Glazing gaskets

- Glazing gaskets are co-extruded onto the beads and profiles

8.5 Glazing packers

- The use of glazing packers is essential to allow the windows or door-sets to function properly. The recommendations for packer locations must be followed. It is of particular importance for glazing units that will be 'Toe and Heeled'
- This procedure ensures that the weight of the glazed unit is correctly supported and does not distort the frame, nor result in the opening light dropping. This affects all side hinged leaves, such as side hung windows, tilt & turn windows and hinged doors, packers should be inserted opposite locking points to aid security
- The interlocking packers **MUST** be adjusted until the frame diagonals are equal. It is recommended that the load bearing packers and location packers are secured in the 'final' position with silicone to prevent them working loose during operation. Care must be taken not to block drainage routes

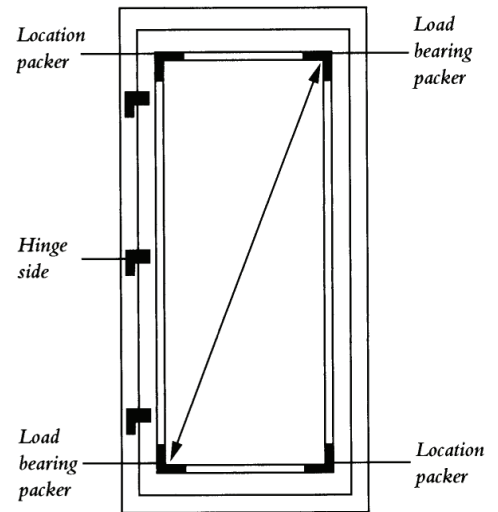

Toe and Heel principle

9.0 INSTALLATION COMPLETION

9.1 Finishing off and making good

Every attempt should be made during installation to ensure that debris such as wet plaster does not block drainage paths or impair the operation of hardware.

Internal reveals should be made good, ready for the customer to redecorate, where appropriate. Neither, cement, nor plaster should be used to fill the gap between the back of the frame and the structural opening.

When it is necessary to seal internally, such sealants should be capable of accepting paint or wallpaper i.e. acrylic sealant. All internal sealant should be flushed off ensuring the frame and reveal are free of surplus sealant. Note: Silicone sealants should not be used between the frame and reveal. If cover trims are required to complete the installation use the minimum width to achieve a satisfactory appearance.

All protective films placed on the profiles during extrusion should be removed as soon as the installation is finished and prior to sealing the perimeter joints.

9.2 Final check and customer product awareness

After installation, a final inspection should be carried out to ensure that the installation is of the highest standard.

It is good practice to ensure that the customer is familiar with the method of operation of the installed windows and door-sets operating features such as opening, key locks, shoot bolts and latches should be demonstrated so that the customer knows how to use them. This is especially important in the case that may be used in fires. Such training is best supplemented with written operating and maintenance instructions.

9.3 Cleaning and maintenance

The pristine appearance of PVC-U windows and door-sets is maintained by occasional cleaning. The frequency of this cleaning will depend on the local conditions. For instance, products installed in an industrially polluted or coastal area are likely to need cleaning more frequently. Particular care should be taken to ensure that nothing, which may cause a rust stain, comes into contact with PVC-U as rust stains are not removable.

The cleaning of both gaskets and profile sections should be carried out periodically to maintain the appearance. Failure to do this will not affect the performance of the products, but will spoil their appearance. Stains that are not removable with soapy water may be removable using a domestic non-abrasive cream cleaner. However these should not be used to excess as they may affect the gloss finish.

On no account should any solvent based cleaners be used without prior approval from the supplier, as some of these may seriously affect the profiles.

This Data has been prepared by Halo, a division of Veka, with reasonable care for general guidance purposes only. Reliance on the information contained in this document shall be the entire responsibility of the person/persons so relying and in no event shall Veka be liable for any direct loss or damage attributable to reliance on this Technical Data Sheet. Under no circumstances shall Veka be liable for any indirect or consequential loss or damage including, but not limited to, loss of profit and loss of contracts. As part of our policy of continuous improvement we reserve the right to alter specifications without prior notice.

© Veka 2012

To discover more on how Halo can help you deliver the sustainable communities agenda and to explore how the services we offer can produce real results, please contact us or visit our website.

©Copyright Veka 2012
We reserve the right to alter specifications in line with our policy of continual product improvement

Tel: 01282 716611
Fax: 01282 725257
Email: salesenquiry@veka.com
Visit: www.halo-uk.com

Address : Halo
Farrington Road
Rossendale Road
Industrial Estate
Burnley
Lancashire
BB11 5DA

